



Surface mounting luminaires

IP 65 Dusttight and Jetproof conforming to DIN, VDE, IEC.
Class I.

This innovative surface mounting unit features energy efficient lamps for functional direct illumination. It provides the most pleasing and even light distribution which facilitates safe pedestrian traffic amongst walkways and stairways by creating visual continuity and highlighting the walkways. The lower lamp wattages have significantly reduced the energy consumption of the units thus reducing the heat generated and the associated running costs.

- Dusttight and Jetproof
- Vandal resistant
- Corrosion resistant die cast aluminium body and faceplate
- Ultraviolet resistant white opal polycarbonate diffuser or safety glass lens on request
- Stainless steel screws
- Silicone rubber gasket
- Integral control gear
- Open with tools only
- M 20x1.5 cable entries diameter 7.5 - 13.5 mm.
- Ultraviolet stabilized polyester powder coat finish in Black RAL 9005
- Other colours available upon consultation

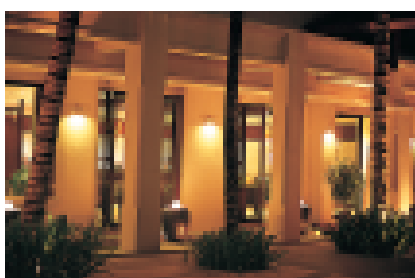
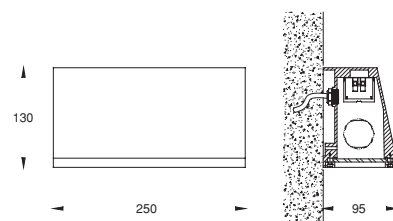
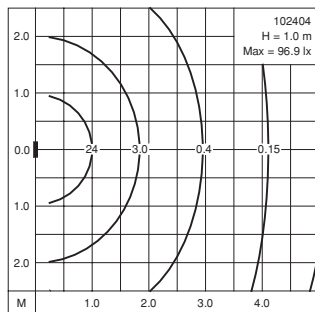
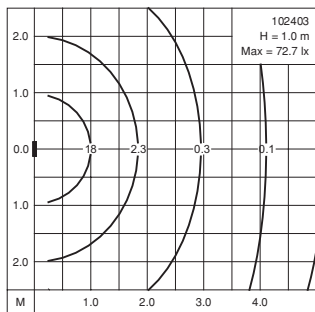

			Lumen
102401	Incandescent	E14 : 40W	400
102402	Compact fluorescent	G23 : 5/7/9W	250/400/600
102403	Compact fluorescent	G24d-1 : 10/13W	600/900
102404	Compact fluorescent	G24d-2 : 18W	1200