



Wall recessed luminaires

IP 65 Dusttight and Jetproof conforming to DIN, VDE, IEC.
Class I.

This innovative wall recessed unit features energy efficient lamps for functional direct illumination. It provides the most pleasing and even light distribution which facilitates safe pedestrian traffic amongst walkways and stairways by creating visual continuity and highlighting the walkways. The lower lamp wattages have significantly reduced the energy consumption of the units thus reducing the heat generated and the associated running costs.

- Dusttight and Jetproof
- Corrosion resistant die cast aluminium body and faceplate
- UV stabilized and vandal resistant polycarbonate diffuser or safety glass lens on request
- Stainless steel screws
- Silicone rubber gasket
- Integral control gear
- Open with tools only
- M 20x1.5 cable entries diameter 7.5 - 13.5 mm.
- Ultraviolet stabilized polyester powder coat finish in Black RAL 9005
- Other colours available upon consultation

- Galvanized steel sheet or aluminium sheet blackout on request

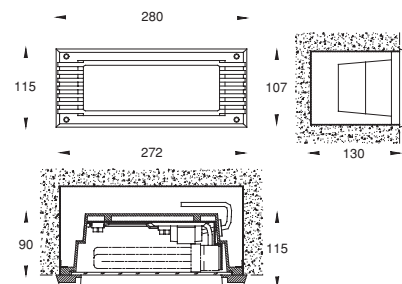
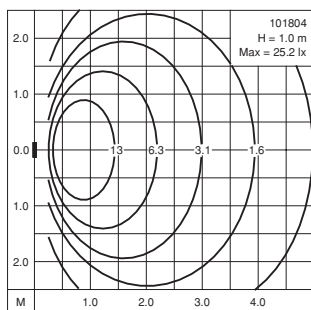
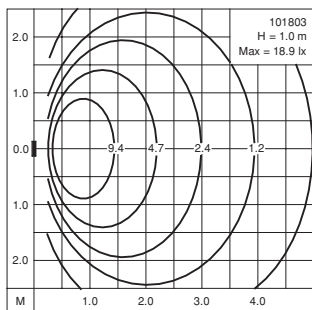

			Lumen
101801	Incandescent	E14 : 40W	400
101802	Compact fluorescent	G23 : 5/7/9W	250/400/600
101803	Compact fluorescent	G24d-1 : 10/13W	600/900
101804	Compact fluorescent	G24d-2 : 18W	1200
101805	Compact fluorescent	G24d-3 : 26W	1800